



MVS Multi-Vessel System

MVS Multi-Vessel System for integrating internal weight measurements and external Kistler-Morse® weight and level measurement indicators.

TECHNICAL SPECIFICATIONS



FEATURES AND BENEFITS

Wide Range of Configurations

Users can match their specific needs for weight and level sensors from the spectrum of Kistler-Morse technologies.

Multiple Input Options

Plug in cards for direct measurement of strain gauges, voltages, and currents. Communications host for Kistler-Morse ultrasonic level units and Kistler-Morse weight indicators. Supports a total of 120 data I/O.

Backlit Display and Sealed Keyboard

Easy access to setup onboard measurements and serially connected Kistler-Morse indicators.

Multiple Output Options

Supports current loops, relays, AB RIO, Modbus RTU, and two channels of ASCII serial data transfers.

Smart Channels

Allows arithmetic combinations of data channels to increase accuracy and versatility by combining input measurements from different channels and sources.

Kistler-Morse's Multi-Vessel System (MVS) is a powerful and versatile, multi-functional signal processor and display for continuous level and weight monitoring and is fully configurable and expandable for up to 120 vessels. Key to Kistler-Morse's modular building block approach for level and weighing inventory systems, it allows configuration of a cost-effective system to suit your unique operational needs. With its on-board serial ports, inter-rack communications, and plug-in option PCB cards, the MVS functions as a stand-alone signal processor and display, yet is easily expanded to communicate and share data with other MVS systems as well as PLC/DCS control systems. The serial port is also a gateway to other Kistler-Morse digital weight and Sonologic level processors for remote display and setup of those systems.

Each MVS is configured with input and output cards to match the specific needs of your application. It allows you to mix and match high density input cards for one of the lowest costs per vessel in the industry, with optional high performance input cards for demanding applications or critical vessels. With the ability of locating Kistler-Morse's load cells and sensors up to 2,000 feet (610 m) away from the processor, it eliminates the need to locate the electronics in the process area. Setpoint output cards can be added to provide local alarms, and analog output cards can be used to retransmit MVS vessel data to PLC/DCS or other analog devices. Select one of the PLC interfaces and digitally transfer vessel data for multiple vessels directly to the PLC without conversion hassles or multiple cable runs.

Two MVS styles are available. The 19-inch rack MVS-8D holds up to eight option cards, suitable for a control room environment. For additional rack space and power needs, the MVS-8N/-8P expansion racks connect directly to the microprocessor bus of an MVS-8D. The NEMA-4X enclosure MVS-4D houses up to four option cards in a wall-mounted enclosure. Both options still allow inter-rack serial data exchanges.



SPECIFICATIONS

| FUNCTIONAL SPECS | Product Name |
|----------------------------|---|
| MVS-4D/8D | Micro PCB: Setup parameter EEPROM, serial ports configurable for RS 232/422/485 (Comm1: selectable master/slave; Comm2: selectable slave/printer) Power Supply PCB: 85-240 VAC 50/60 Hz universal input, 85 watts maximum |
| MVSS-8P | Power Supply PCB: 85-240 VAC 50/60 Hz universal input, 85 watts maximum |
| PERFORMANCE SPECIFICATIONS | |
| PCB Options Cards | 8-Channel ADC Strain Input PCB: Configurable for Kistler-Morse sensor/load cell transducer or 4-wire full-bridge foil gage load cells (per PCB) Excitation: Adjustable 5-13 VDC at 664 mA (per PCB) Input range: ± 1.0 VDC or ± 50 mVDC (per PCB) Resolution: 16-bit |
| | 8-Channel Current Input PCB: Input range: Configurable for 0-20 mA or 4-20 mA (per PCB) Resolution: 16-bit 8-Channel Voltage Input PCB: Input range: Configurable for 0-5 VDC or 0-10 VDC (per PCB) Resolution: 16-bit |
| | 8-Channel ADC/Regulator Strain Input PCB: (requires 2 option slots, first slot requiring 8-channel ADC Strain Input PCB) Sense line connection for Kistler-Morse sensor/load cell transducer through intrinsically safe barriers or 6-wire foil gage load cells Excitation: Adjustable 5-13 VDC at 664 mA (per PCB) Input range: ± 1.0 VDC or ± 50 mVDC (per PCB) Resolution: 16-bit |
| | MVS-STX ADC Strain Input (single channel) PCB: Configurable for Kistler-Morse sensor/load cell transducer, 4- or 6-wire full-bridge foil gage load cells, current input, voltage input; includes sense line connection for KM sensor/load cell transducer through intrinsically safe barriers or 6-wire full-bridge foil gage load cells Excitation: Adjustable 5-13 VDC at 114 mA Input range: Adjustable ± 3.0 V at 12 V excitation, Gain = 1; ± 19.5 mV at 10 V excitation, Gain = 128 Resolution: Adjustable 16-bit to 21-bit Filter: Sentry™ digital filter Dedicated RS 422/485 serial output Optional current output: 0-20 mA or 4-20 mA |
| | 8-Channel Remote Tare Input PCB: (VAC standard, optional VDC) Requires momentary dry contact input Input voltage range: 90-140 VAC, 3-32 VDC |
| PHYSICAL SPECIFICATIONS | |
| MVS-4D/8D | Display: Backlit, 2-line, 16 alphanumeric character LCD; user-selectable engineering units; display value; decimal point Interface Keypad: Sealed tactile membrane; keys for alphanumeric entry, function, enter, shift, backspace, escape, manual/automatic display scan, net/gross weight select, tare vessel weight |
| MVS-8D-AC | Main Rack: 19-inch Rack 3U High; 8 Option Slots; MVS-8N/-8P Expansion Rack Connection (I2C); optional dust-tight, drip-proof NEMA-12 enclosure |
| MVS-8N | Blind expansion rack (requires MVS-8D-AC): 19-inch Rack 3U high; 8 option slots; expansion rack connection (I2C) |
| MVS-8P | Blind expansion rack with power supply (requires MVS-8D-AC): 19-inch Rack 3U high; 8 option slots; expansion rack connection (I2C); |
| MVS-4D-AC | NEMA 4X FRP (Fiberglass Reinforced Polyester) enclosure, optional NEMA 4X SS enclosure, 4 Option Slots |

ENCLOSURE DIMENSIONS

MVS-4D Stainless Steel NEMA 4X

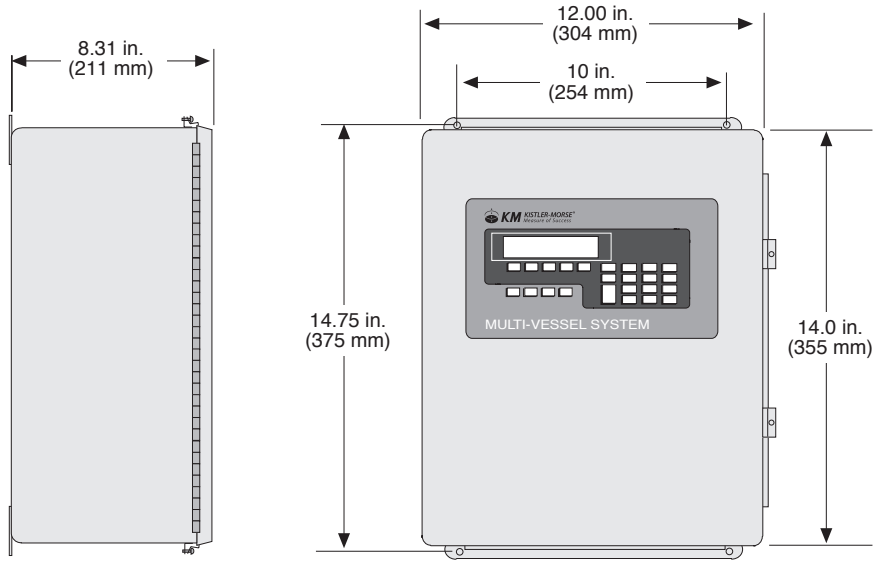

MVS-4D Fiberglass NEMA 4X

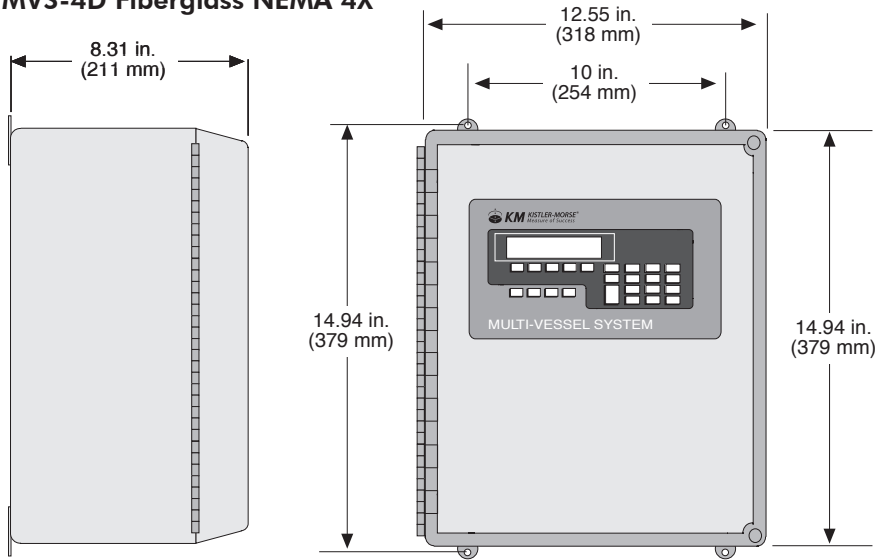

MVS-8D 19 inch Rack Dimensions

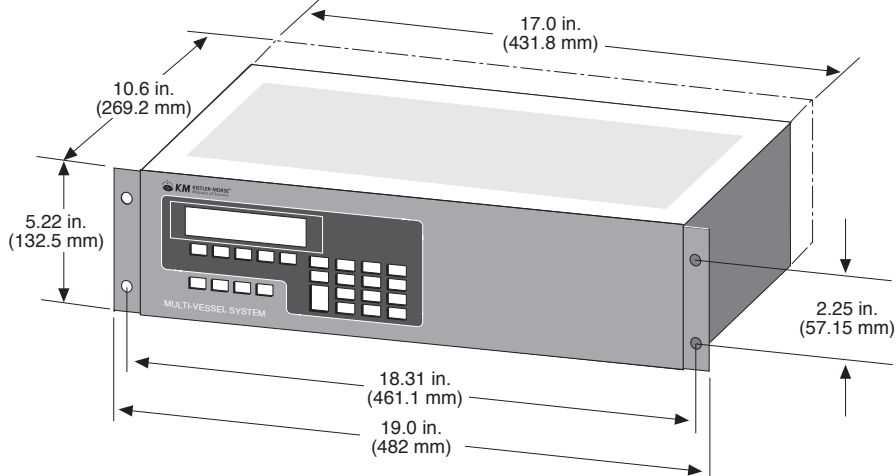

MVS INDICATOR

